

# OEM Output Filter **BOF-2**

Datasheet

Made in  
Germany

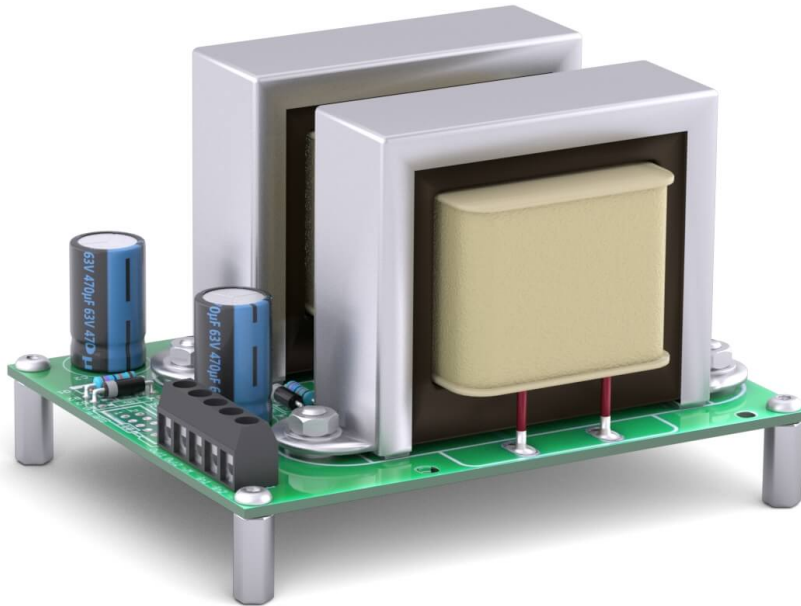

## Functions

The BELEKTRONIG OEM output filter BOF-2 converts an AC voltage into a DC voltage. It filters PWM signals up to 10 A and 36 V, in a frequency range of 1...50 kHz. In combination with the built-in temperature controllers from BELEKTRONIG, the output voltage of the controller can be limited to the permissible values for the used Peltier element, such as 2.2 V or 8.7 V, regardless of the rated voltage of the power supply. In addition, the output filter BOF-2 significantly reduces the induction currents accompanying the PWM signal, preventing crosstalk to sensitive measurement electronics.

**Note:** The OEM output filter BOF-2 is not suitable for pure AC signals. An input voltage  $U_{in} > 0$  V is required.

## Key Features

- ✓ OEM high power LC filter
- ✓ Permissible operating current: 10 A
- ✓ Permissible operating voltage: 36V
- ✓ PWM input frequency: 1...50 kHz
- ✓ Limits the output voltage of PWM signals
- ✓ Controlling Peltier elements regardless of the rated voltage of the used power supply
- ✓ Reduces EMC influences at the voltage output
- ✓ Optimized for operation with BELEKTRONIG built-in temperature controllers

**Application Example: Linearization of PWM Signal of BELEKTRONIG Built-in Controller**

**Connection Example for Controlling of Heating or Peltier Elements with DC Voltage**

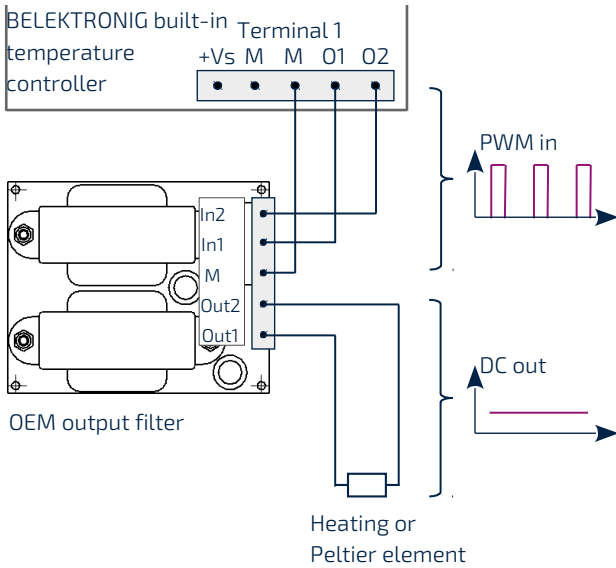

**Limitation of Output Voltage Calculating and Setting the Maximum Duty Cycle**

Example: Controlling a Peltier element with the maximum permissible voltage of 15.8 V, when using a power supply with a rated voltage of 24 V.

Since the voltage of the PWM signal in the "on" cycle is always 24 V, this Peltier element can not be operated directly with the given power supply.

Given:  $U_{in\ PWM-Signal}$ : 0 V; 24 V  
 PWM frequency: 20 kHz

Wanted: Value of duty cycle

Solution:

$$Duty\ cycle_{Max} = \frac{U_{Max}}{U_{Power\ supply}} \cdot 100 = \frac{15.8\ V}{24\ V} \cdot 100 = 65.8\ \%$$

The duty cycle of the built-in temperature controller must be limited to 65.8% in order to be able to operate the Peltier element without overvoltage.

The damping factor at a PWM frequency of 20 kHz is 1/10000. The residual ripple at the maximum output voltage of 15.8 V is 1.58 mV.

**Dimensions in mm**

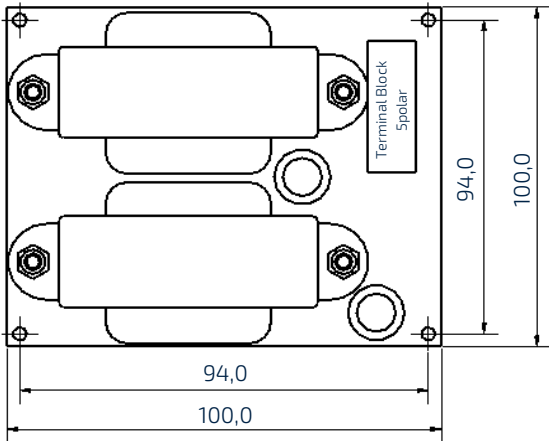

Full height without spacers: 55 mm

**Frequency Response and Attenuation Factor (simulated)**

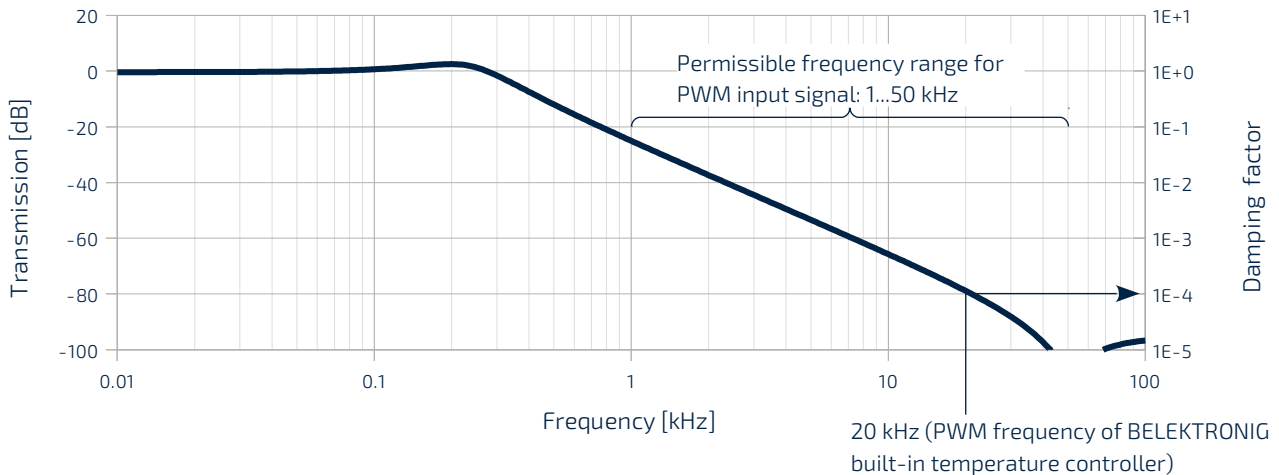

Technical modifications and errors excepted. Images similar. Last update: 01/08/2026

**Technical Data**

**General Properties**

- › OEM high power LC filter
- › Converts PWM signals into DC signals
- › Reduces EMC influences at the voltage output
- › Optimized for operation with BELEKTRONIG built-in temperature controllers
- › RoHS compliant

**Electrical Properties**

- › Permissible operating current: 0...10 A
- › Permissible operating voltage: 0...36 V
- › PWM input frequency: 1...50 kHz
- › Attenuation/ residual ripple: 40 dB (starting with 5 kHz)
- › Internal resistance: 0.04 Ω

**Dimensions and Conditions of Operation**

- › Dimensions (L x W x H): 100 x 80 x 55 mm<sup>3</sup>
- › Weight: 0.95 kg
- › Operating temperature: 10...45°C
- › Relative humidity: 0...80%, not condensating

**Scope of Delivery**

- › OEM output filter BOF-2
- › Assembly material: 4 spacer M3x14  
4 spacer M3x60  
8 allen screws M3x8

**Optimized for fast assembly in Laboratory Equipment and Analytical Instruments and for Operation with BELEKTRONIG Built-in Temperature Controllers**

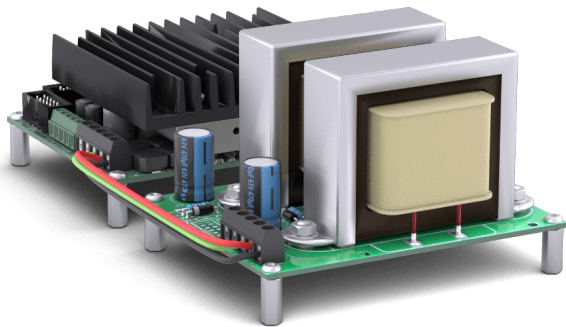

- › Separate mounting side-by-side
- › Space saving mounting option for analytical instruments with low height

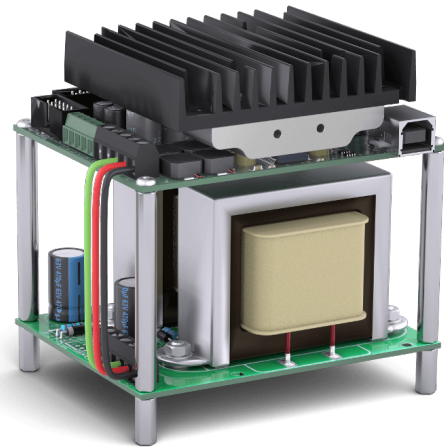

- › Mounting as piggyback
- › Space saving mounting option for laboratory equipment with a small footprint

Learn more about the quality standards of BELEKTRONIG and easily request a quote for your individual experimental setups.  
Dr.-Ing. Glen Guhr and Dr.-Ing. Raimund Bruenig

